



Product Specification [产品规格书]:	Document No.	PS-1004-01
Subject [主题]:	Date Issued	2021/03/29
1.00mm Pitch 1004 Series Connector Specification	Date Revised	
	Version	A

This specification is referred to the 1.00mm series wire to board connector

索引【INDEX】

1. 适用范围【Scope】
2. 规格与料号【Spec and Part number】
3. 材质与表面处理【Material &Surface Treatment】
4. 额定等级&适用电线【Ratings and applicable wires】
5. 性能【Performance】
 - 5-1. 电气的性能【Electrical Performance】
 - 5-2. 机械的性能【Mechanical Performance】
 - 5-3. 环境性能及其它【Environmental Performance and Others】
6. 综合插入力及拔出力【Insertion/Withdrawal Force of Connector】
7. SMT回流条件【SMT Reflow Condition】
8. 产品图示



Product Specification [产品规格书]:	Document No.	PS-1004-01
Subject [主题]:	Date Issued	2021/03/29
1.00mm Pitch 1004 Series Connector Specification	Date Revised	
	Version	A

【1.适用范围 Scope】

此种规格包括 1.00mm Pitch 1004 Series 连接器规格说明。

This Specification Covers the 1.00mm Pitch 1004 Series Connector Specification.

【2.规格与料号 Spec and Part number】

规格内容 Specification	产品料号 Product No.	产品图示 Picture of Product
端子/Terminal	1004T-PXXX	
胶壳/Housing	1004H-XXX-N0NC	
针座/Wafer	1004WRS-XXX-XXXXXXX 1004WVS-XXX-XXXXXXX	

【3.材质与表面处理 Material & Surface Treatment】

规格内容 Specification	材质 Materials	表面处理 Disposal of Surface	
端子/Terminal	磷铜(C5191)/Phosphor Bronze	Nickel Plated: 50u" Min Bright Tin Plated: 100u" Min	
胶壳/Housing	PA66	UL 94V-0	
针座/Wafer	Base	PA4T	UL 94V-0
	PIN	磷铜(C5191)/ Phosphor Bronze	Nickel Plated: 50u" Min Matte Tin Plated: 100u" Min
	Solder tab	黄铜(C2680)/Brass	Nickel Plated: 50u" Min Matte Tin Plated: 100u" Min

(上述参数请以工程图为准/Please Refer to the Project drawing for the above Specification)

【4. 额定等级 Ratings and applicable wires】

项目【Item】	规格【Standard】
4-1. 额定电压 Rated Voltage (Max.)	100V
4-2. 额定电流 Rated Current (Max.)	AWG#28 1A
	AWG#30 1A
	AWG#32 0.8A
4-3. 使用温度范围 Ambient temperature Range	-40°C~+105°C
4-4. 适用线径 Applicable wire insulation AWG(mm ²)	AWG#28~32 绝缘Ø O.D : 0.4~0.8mm(Max.)

【 *升温时含端子.Including terminal temperature rise. 】



Product Specification [产品规格书]:	Document No.	PS-1004-01
Subject [主题]:	Date Issued	2021/03/29
1.00mm Pitch 1004 Series Connector Specification	Date Revised	
	Version	A

【5.性能 PERFORMANCE】

5-1. 电气的性能 Electrical Performance.

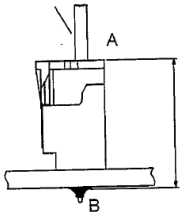
项 目 【Item】	条 件 【Test Condition】	规 格 【Requirement】
5-1-1 接触阻抗 Contact Resistance	公母配合,开放电压 20mV 以下,电流 10mA 检测连接器 A~B 区。 Mate connectors, measure by dry circuit, 20mV MAX, 10mA. (Based upon EIA-364-06A). 	Initial: 20 milliohms Max. After Test: 40 milliohms Max.
5-1-2 绝缘阻抗 Insulation Resistance	公母配合,在相邻端子,端子与地片之间,使用 500V 的直流电,检测连接器。 Mate connectors, apply 500V DC between adjacent terminal or ground. (Based upon EIA-364-21B / MIL-STD-202 Method 302 Cond.B)	100 Megohms Min.
5-1-3 耐电压 Dielectric Strength	公母配合,在相邻端子,端子与地片之间,使用 300V 的交流电 1 分钟,检测连接器。 Mate connectors, apply 300V AC for 1 minute between adjacent terminal or ground. (Based upon EIA-364-20A / MIL-STD-202 Method 301)	外观无损伤, 无打火花 No Breakdown and Flashover
5-1-4 铆线后端子接触阻抗 Contact resistance on crimped portion	铆线后之端子,开放电压 20mV 以下,电流 10mA 检测连接器。 Crimp the applicable wire on to the terminal measure by dry circuit 20mV MAX, 10mA.	5.0 milliohms Max.



Product Specification [产品规格书]:	Document No.	PS-1004-01
Subject [主题]:	Date Issued	2021/03/29
1.00mm Pitch 1004 Series Connector Specification	Date Revised	
	Version	A

5-2. 机械的性能 Mechanical Performance.

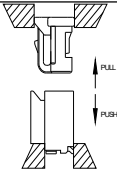
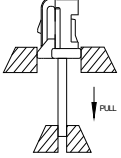
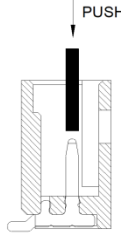
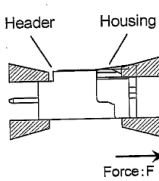
项 目 【Item】		条 件 【Test Condition】	规 格 【Requirement】		
5-2-1	插拔力 Insertion & Withdraw Force	<p>以每分钟 $25.4\pm 3\text{mm}$ 的速率插入和拔出。 Insert and withdraw Connectors at the speed rate of $25.4\pm 3\text{mm/minute}$.</p> 	参照第 6 项 Refer to paragraph 6		
5-2-2	端子保持力 Terminal/Housing Retention Force	<p>以每分 $25.4\pm 3\text{mm}$ 的速率,将端子从 Housing 内轴向拔出的力量。 Apply axial pull out force at the speed rate of $25.4\pm 3\text{mm/minute}$ on the terminal assembled in the housing.</p> 	4.9N {0.5kgf} Min.		
5-2-3	端子插入力 Terminal Insertion Force	<p>铆线后之端子插入 Housing 所需最大力量。 Insert the crimped terminal into the housing.</p>	4.9N {0.5kgf} Max.		
5-2-4	Pin 针保持力 Pin Retention Force	<p>以每分 $25.4\pm 3\text{mm}$ 的速率,将 PIN 针从 Wafer 内轴向拔出的力量。 Apply axial push force at the speed rate of $25.4\pm 3\text{mm/minute}$.</p> 	3.0N {0.3kgf}Min.		
5-2-5	Lock 保持力 Lock Retention Force	<p>将 Housing 与 Wafer 匹配后, 将 Housing 从 Wafer 内轴向拔出的力量, 看其卡扣的承受力量 A housing and a header shall be mated, Pulling load shall be applied them, the load to make them come off each other shall be measured</p> 	内锁型, 6-15P Inner Lock, 6-15P 19.6N {2.0kgf} min.		
			Outer Lock 外锁型, 3-5P		
			3PIN	4PIN	5PIN
		9.8N{1 kgf} MIN.	19.6N{2 kgf} MIN.	19.6N{2 kgf} MIN.	



Product Specification [产品规格书]:	Document No.	PS-1004-01
Subject [主题]:	Date Issued	2021/03/29
1.00mm Pitch 1004 Series Connector Specification	Date Revised	
	Version	A

项目 【Item】	条件 【Test Condition】	规格 【Requirement】			
5-2-6 端子压着强度 Crimped contact	固定铆线后的端子，使电线与端子分离时所需的最小力量。 Fix the crimped terminal, apply axial pull out force on the wire. (Do not crimp insulation part).	AWG 线号	AWG# 28	AWG#30	AWG# 32
		Spec.kgf. Min.	1.0 {9.8N}	0.5 {4.9N}	0.3 {3.0N}
		Note> As for unspecified wire sizes in this specification define values with customer.			

5-3. 环境性能及其它 Environmental Performance and Others

项目 【Item】	条件 【Test Condition】	规格 【Requirement】	
5-3-1 重复插拔 Repeated Insertion/ Withdrawal	以每分钟不超过 10 次的速率,将公母插拔 30 次。 When mated up to 30 cycles repeatedly by the rate of 10 cycles per minute.	接触阻抗 Contact Resistance	40 milliohms Max.
5-3-2 温升测试 Temperature Rise	公母连接器配合后，加载额定电流直到温度上升到稳定状态，然后再测量温升（EIA364-70,Method 1） Mating connectors shall be energized at rating current until thermal stability is achieved, and then measured the temperature rise. (EIA364-70,Method 1)	温升测试 Temperature rise	30°C Max.
5-3-3 振动测试 Vibration test	振幅: 1.52mm P-P 时间: 10~55~10 Hz in 1minute 持续时间: 每轴向 2 小时 加速度: 44m/S ² 开放电压: 20mV 以下 开放电流: 10mA 以下 Amplitude: 1.52mm P-P Sweep time: 10~55~10 Hz in 1 minute Duration: 2 hours in each X.Y.Z axials. (Based upon EIA-364-28B/MIL-STD-202 Method 201)	外观 Appearance	无异状 No Damage
		接触阻抗 Contact Resistance	40 milliohms Max.
		瞬断 Discontinuity	1 micro-second Max.
5-3-4 冲击测试 Shock test	在 X.Y.Z 上 6 个方向上,以 490m/s ² (50G 的力量)冲击下各 3 回。作用时间: 11ms 490m/s ² {50G}, 3 strokes in each X.Y.Z. axes. Operation time:11ms (Based upon EIA-364-27B/MIL-STD-202 Method 213)	外观 Appearance	无异状 No Damage
		接触阻抗 Contact Resistance	40 milliohms Max.
		瞬断 Discontinuity	1 micro-second Max.



Product Specification [产品规格书]:	Document No.	PS-1004-01
Subject [主题]:	Date Issued	2021/03/29
1.00mm Pitch 1004 Series Connector Specification	Date Revised	
	Version	A

项 目 【Item】		条 件 【Test Condition】	规 格 【Requirement】	
5-3-5	耐热性 Heat Resistance	105±2°C,96 hours. (Based upon MIL-STD-202 Method 108A Cond.A)	外观 Appearance	无异状 No Damage
			接触阻抗 Contact Resistance	40 milliohms Max.
5-3-6	耐寒性 Cold Resistance	-40±3°C,96 hours. (Based upon EIA-364-105)	外观 Appearance	无异状 No Damage
			接触阻抗 Contact Resistance	40 milliohms Max.
5-3-7	耐湿性 Humidity	温度: 60±2°C 湿度: 90~95%(RH) 持续时间: 96 hours Temperature: 60±2°C Relative Humidity: 90~95% Duration: 96 hours (Based upon EIA-364-31A/MIL-STD-202 Method 103B Cond.B)	外观 Appearance	无异状 No Damage
			接触阻抗 Contact Resistance	40 milliohms Max.
			耐电压 Dielectric Strength	Must meet 5-1-3
			绝缘阻抗 Insulation Resistance	10 Megohms Min.
5-3-8	温度变化 Temperature Cycling	从-40°C持续 30 分钟升至+105°C持续 30 分钟,循环 5 次. 5 cycles of: a) -40°C 30 minutes. b) +105°C 30 minutes. (Based upon EIA-364-32B)	外观 Appearance	无异状 No Damage
			接触阻抗 Contact Resistance	40 milliohms Max.
5-3-9	盐水喷雾 Salt Spray	在温度 35±2°C,盐水浓度 5±1%下,盐水喷雾 48±4 小时. 48±4 hours exposure to a salt spray from the 5±1% solution at 35±2°C. (Based upon EIA-364-26A/MIL-STD-202 Method 101D Cond.B).	外观 Appearance	无异状 No Damage
			接触阻抗 Contact Resistance	40 milliohms Max.
5-3-10	焊锡附着性 Solder-ability	焊接时间: 3~5 秒. 焊接温度: 245±5°C. Soldering time: 3~5sec solder. Temperature: 245±5°C.	Solder Wetting	沾锡面积需 95% 以上 95% of immersed area must show no voids, pin holes.



Product Specification [产品规格书]:	Document No.	PS-1004-01
Subject [主题]:	Date Issued	2021/03/29
1.00mm Pitch 1004 Series Connector Specification	Date Revised	
	Version	A

5-3-11	焊锡耐热性 Resistance to Soldering Heat	<p>焊接时间: 5~10 秒. 焊接温度: 255+5/-5°C. Soldering time:5~10 sec solder. Temperature:255+5/-5°C. (Based upon EIA-364-56A)</p>	外观 Appearance	无异状 No Damage
		<p>Reflow by Manual Soldering iron: Using a soldering iron (370~400° C for 3 ± 1 seconds) heat up the area 0.2mm from the tip of the solder tails and fitting nails. However, do not apply excessive pressure to either the terminals or fitting nails.</p>	外观 Appearance	无异状 No Damage
5-3-12	耐亚硫酸腐蚀性 SO ₂ gas	<p>将公母对插好的样品放入温度 40±2°C，亚硫酸浓度在 50±5ppm 环境中放置 24 小时。 Mated connectors and expose to the conditions of 50 ± 5ppm SO₂ gas ambient temperature 40 ± 2° C for 24 hours.</p>	外观 Appearance	功能无损坏 No Damage on function
			接触阻抗 Contact Resistance	40 milliohms Max.
5-3-13	耐氨性 NH ₃ Gas	<p>将公母对插好的样品, 在浓度为 28%的氨水的容器中放置 40 分钟。(1L 与 25ml 的比例) Mated connectors and expose to the conditions of NH₃ gas evaporating from 28% NH₃ solution for 40 minutes. (Rate is 25ml per 1L)</p>	外观 Appearance	功能无损坏 No Damage on function
			接触阻抗 Contact Resistance	40 milliohms Max.



Product Specification [产品规格书]:	Document No.	PS-1004-01
Subject [主题]:	Date Issued	2021/03/29
1.00mm Pitch 1004 Series Connector Specification	Date Revised	
	Version	A

【6.综合插入力及拔出力 INSERTION/WITHDRAWAL FORCE】 <Connector mating force>

PIN 数 No. of CKT	初次插入力(最大值) First Insertion (kgf Max.)	30 次拔出力(最小值) 30 th Withdrawal (kgf Min.)	PIN 数 No. of CKT	初次插入力(最大值) First Insertion (kgf Max.)	30 次拔出力(最小值) 30 th Withdrawal (kgf Min.)
Inner Lock 内锁型					
Single	/	/	09	2.02{19.8N}	0.13{1.3N}
02	1.45{14.2N}	0.13{1.3N}	10	2.24{22.0N}	0.14{1.4N}
03	1.67{16.4N}	0.14{1.4N}	11	2.47{24.2N}	0.16{1.5N}
04	1.9{18.6N}	0.16{1.6N}	12	2.69{26.4N}	0.17{1.7N}
05	2.12{20.8N}	0.17{1.7N}	13	2.92{28.6N}	0.19{1.8N}
06	1.35{13.2N}	0.09{0.8N}	14	3.14{30.8N}	0.20{2.0N}
07	1.57{15.4N}	0.10{1.0N}	15	3.37{33.0N}	0.21{2.1N}
08	1.80{17.6N}	0.11{1.1N}			
Outer Lock 外锁型					
Single	/	/	05	1.12 {11N}	0.07 {0.67N}
03	0.67 {6.6N}	0.04 {0.4N}			
04	0.89 {8.8N}	0.05 {0.53N}			

注：以上插拔次数为 30 次

Note: Insertion and Withdrawal for 30Cycles



Product Specification [产品规格书]:	Document No.	PS-1004-01
Subject [主题]:	Date Issued	2021/03/29
1.00mm Pitch 1004 Series Connector Specification	Date Revised	
	Version	A

【7. SMT 回流条件 SMT REFLOW CONDITION】

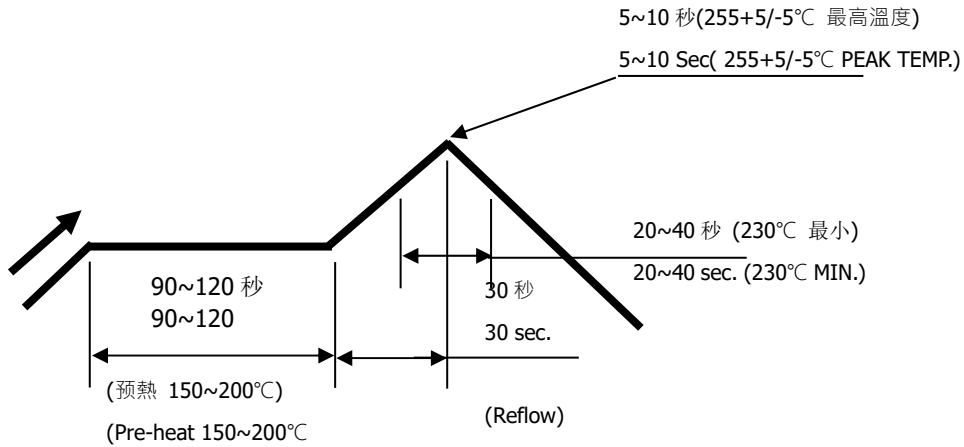

温度条件曲线图/ 基板上温度

TEMPERATURE CONDITION GRAPH/ (TEMPERATURE ON BOARD PATTERN SIDE)

注记: 由于 P.C 板等焊接装置改变条件,所以请预先用自己的装置检查回流焊的条件.

Notes: Please check the reflow soldering condition by your own devices beforehand. Because the condition changes by the soldering devices, P.C. boards, and so on.



Product Specification [产品规格书]:	Document No.	PS-1004-01
Subject [主题]:	Date Issued	2021/03/29
1.00mm Pitch 1004 Series Connector Specification	Date Revised	
	Version	A

【8. 产品图示 PRODUCT PICTURE】

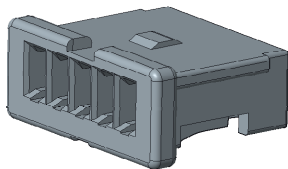
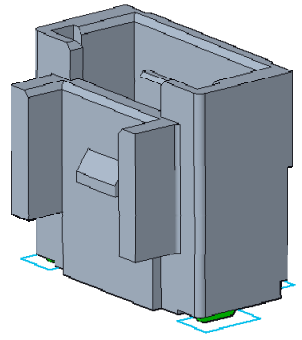
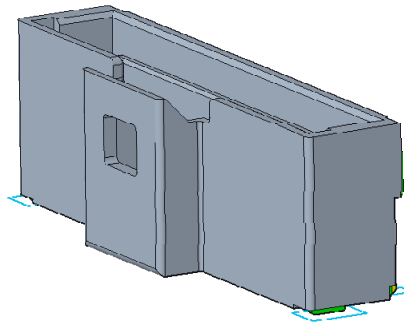
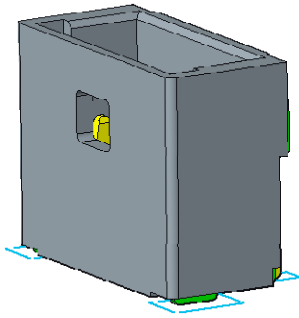
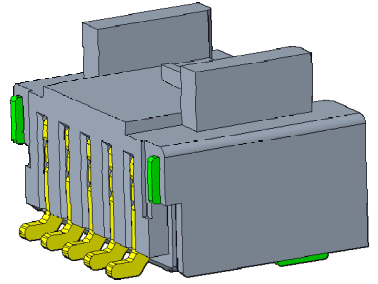
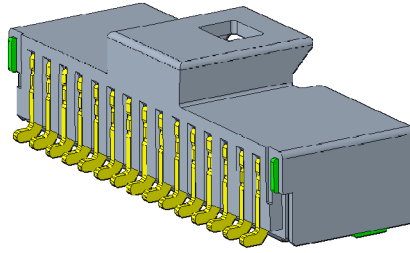
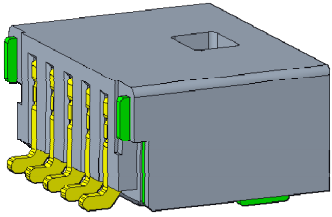

2-5P

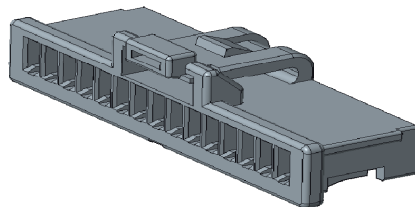

6-15P

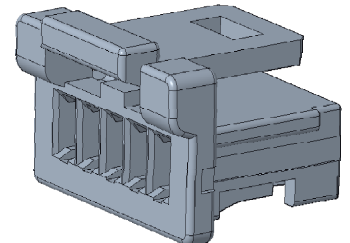

3-5P

Inner Lock 内锁型

Outer Lock 外锁型